

644J and 724J Loader Repair

TECHNICAL MANUAL 644J and 724J Loader Repair TM2076

TM2076 17OCT06 (ENGLISH)

For complete service information also see:

644J and 724J Loader Operation and Test	TM2075
724J Loader Operator's Manual (S.N. — 590067).....	OMT182027
644J and 724J Loader Operator's Manual (S.N. 590068—).....	OMT200782
Alternators and Starting Motors.....	CTM77
POWERTECH® 8.1 L Diesel Engines Base Engine	CTM86
TeamMate™ III 1000, 1200, and 1400 Series Inboard Planetary Axles	CTM150
POWERTECH® 8.1 L Diesel Engines Level 9 Electronic Fuel System with Denso HPCR	CTM255
Super Caddy Oil Cleanup Procedure.....	CTM310
120 Series Hydraulic Cylinders	TM-H120A
185 Series Hydraulic Cylinders	TM-H185A
SERVICE ADVISOR™ System Computer Connection.....	T133991

**Worldwide Construction
And Forestry Division**

LITHO IN U.S.A.

Introduction

Foreword

This manual is written for an experienced technician. Essential tools required in performing certain service work are identified in this manual and are recommended for use.

Live with safety: Read the safety messages in the introduction of this manual and the cautions presented throughout the text of the manual.



This is the safety-alert symbol. When you see this symbol on the machine or in this manual, be alert to the potential for personal injury.

Technical manuals are divided in two parts: repair and operation and tests. Repair sections tell how to repair the components. Operation and tests sections help you identify the majority of routine failures quickly.

Information is organized in groups for the various components requiring service instruction. At the beginning of each group are summary listings of all applicable essential tools, service equipment and tools, other materials needed to do the job, service parts kits, specifications, wear tolerances, and torque values.

Technical Manuals are concise guides for specific machines. They are on-the-job guides containing only the vital information needed for diagnosis, analysis, testing, and repair.

Fundamental service information is available from other sources covering basic theory of operation, fundamentals of troubleshooting, general maintenance, and basic type of failures and their causes.

DX, TMIFC -19-29SEP98-1/1

**Thanks very much for your reading,
Want to get more information,
Please click here, Then get the complete
manual**

JustClickHere 

NOTE:

**If there is no response to click on the link above,
please download the PDF document first, and then
click on it.**

**Have any questions please write to me:
admin@servicemanualperfect.com**

Contents

SECTION 00—General Information

Group 0001—Safety Information

SECTION 01—Wheels

Group 0110—Powered Wheels And Fasteners

SECTION 02—Axles And Suspension Systems

Group 0200—Removal And Installation
Group 0225—Input Drive Shafts And U-Joints
Group 0250—Axle Shaft, Bearings, And Reduction Gears
Group 0260—Hydraulic System

SECTION 03—Transmission

Group 0300—Removal And Installation
Group 0350—Gears, Shafts, Bearings And Power Shift Clutch
Group 0360—Hydraulic System

SECTION 04—Engine

Group 0400—Removal And Installation

SECTION 05—Engine Auxiliary Systems

Group 0505—Cold Weather Starting Aids
Group 0510—Cooling System
Group 0515—Speed Controls
Group 0520—Intake System
Group 0530—External Exhaust System
Group 0560—External Fuel Supply Systems

SECTION 07—Dampener Drive

Group 0752—Elements

SECTION 09—Steering System

Group 0960—Hydraulic System

SECTION 10—Service Brakes

Group 1011—Active Elements
Group 1060—Hydraulic System

SECTION 11—Park Brake

Group 1111—Active Elements
Group 1160—Hydraulic System

SECTION 17—Frame Or Supporting Structure

Group 1740—Frame Installation
Group 1746—Frame Bottom Guards
Group 1749—Chassis Weights

SECTION 18—Operator's Station

Group 1800—Removal And Installation
Group 1810—Operator Enclosure
Group 1830—Heating And Air Conditioning

SECTION 19—Sheet Metal And Styling

Group 1910—Hood Or Engine Enclosure
Group 1921—Grille And Grille Housing

SECTION 31—Loader

Group 3102—Bucket
Group 3140—Frames
Group 3160—Hydraulic System

SECTION 9900—Dealer Fabricated Tools

Group 0099—Dealer Fabricated Tools

All information, illustrations and specifications in this manual are based on the latest information available at the time of publication. The right is reserved to make changes at any time without notice.

COPYRIGHT © 2006
DEERE & COMPANY
Moline, Illinois
All rights reserved
A John Deere ILLUSTRATION® Manual
Previous Editions
Copyright © 2003, 2004

Contents

00

01

02

03

04

05

07

09

10

11

Contents

17

18

19

31

9900

INDX

Contents

17

18

19

31

9900

INDX

Section 00

General Information

Contents

	Page
Group 0001—Safety Information	
Recognize Safety Information	00-0001-1
Follow Safety Instructions	00-0001-1
Operate Only If Qualified.	00-0001-2
Wear Protective Equipment.	00-0001-2
Avoid Unauthorized Machine	
Modifications	00-0001-2
Add Cab Guarding For Special Uses	00-0001-3
Inspect Machine	00-0001-3
Stay Clear of Moving Parts	00-0001-3
Avoid High-Pressure Oil	00-0001-4
Beware of Exhaust Fumes	00-0001-4
Prevent Fires.	00-0001-5
Prevent Battery Explosions	00-0001-5
Handle Chemical Products Safely	00-0001-6
Dispose of Waste Properly	00-0001-6
Prepare for Emergencies.	00-0001-6
Use Steps and Handholds Correctly	00-0001-7
Start Only From Operator's Seat.	00-0001-7
Use and Maintain Seat Belt.	00-0001-7
Prevent Unintended Machine Movement.	00-0001-8
Avoid Work Site Hazards	00-0001-8
Use Special Care When Operating	
Loader.	00-0001-9
Keep Riders Off Machine	00-0001-9
Avoid Backover Accidents.	00-0001-10
Avoid Machine Tip Over	00-0001-10
Operating on Slopes	00-0001-11
Operating Or Traveling On Public Roads	00-0001-11
Inspect and Maintain ROPS	00-0001-12
Add and Operate Attachments Safely	00-0001-12
Park And Prepare For Service Safely	00-0001-13
Service Cooling System Safely	00-0001-13
Remove Paint Before Welding or	
Heating	00-0001-14
Make Welding Repairs Safely	00-0001-14
Drive Metal Pins Safely	00-0001-15

Recognize Safety Information

This is the safety alert symbol. When you see this symbol on your machine or in this manual, be alert for the potential of personal injury.

Follow the precautions and safe operating practices highlighted by this symbol.

A signal word — DANGER, WARNING, or CAUTION — is used with the safety alert symbol. DANGER identifies the most serious hazards.

On your machine, DANGER signs are red in color, WARNING signs are orange, and CAUTION signs are yellow. DANGER and WARNING signs are located near specific hazards. General precautions are on CAUTION labels.



T133555 -UN-28AUG00

T133588 -19-28AUG00

TX03679.00016CC -19-01SEP06-1/1

Follow Safety Instructions

Read the safety messages in this manual and on the machine. Follow these warnings and instructions carefully. Review them frequently. Keep safety signs in good condition. Replace missing or damaged safety signs. Be sure new equipment components and repair parts include the current safety signs. Replacement safety signs are available from your John Deere dealer.

Be sure all operators of this machine understand every safety message. Replace operator's manual and safety labels immediately if missing or damaged.



T133556 -UN-24AUG00

TX03679.00016F9 -19-11AUG03-1/1

00
0001
2

Operate Only If Qualified

Do not operate this machine unless you have read the operator's manual carefully and you have been qualified by supervised training and instruction.

Familiarize yourself with the job site and your surroundings before operating. Try all controls and

machine functions with the machine in an open area before starting to work.

Know and observe all safety rules that may apply to your work situation and your work site.

TX03679,00016FA -19-01SEP06-1/1

Wear Protective Equipment

Guard against injury from flying pieces of metal or debris; wear goggles or safety glasses.

Wear close fitting clothing and safety equipment appropriate to the job.

Prolonged exposure to loud noise can cause impairment or loss of hearing. Wear suitable hearing protection such as earmuffs or earplugs to protect against objectionable or uncomfortable loud noises.

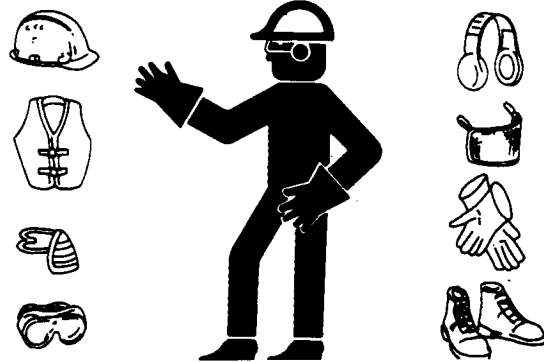

TS206 -JUN-23AUG88

TX03679,00016D0 -19-01SEP06-1/1

Avoid Unauthorized Machine Modifications

Modifications of this machine, or addition of unapproved products or attachments, may affect machine stability or reliability, and may create a hazard for the operator or others near the machine. The installer of any modification which may affect the electronic controls of this machine is responsible for establishing that the modification does not adversely affect the machine or its performance.

Always contact an authorized dealer before making machine modifications that change the intended use, weight or balance of the machine, or that alter machine controls, performance or reliability.

TX03679,00016B7 -19-11AUG03-1/1

Add Cab Guarding For Special Uses

Special work situations or machine attachments may create an environment with falling or flying objects. Loading logs, using fork attachments, or operating in waste management applications requires special work tools. Added cab guarding to protect the operator may also be required.

Use load-clamping grapples to keep bulky loads from falling and add special screens or guarding when objects may be directed toward the cab. Contact your authorized dealer for information on devices intended to protect the operator from falling or flying objects in special work situations.

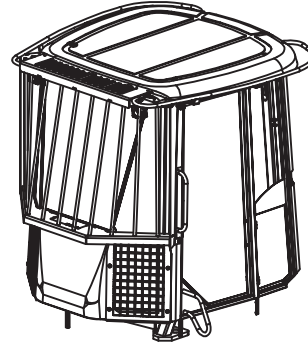

T141893 -UN-04MAY01

TX03679.00017C6 -19-01JUN01-1/1

Inspect Machine

Inspect machine carefully each day by walking around it before starting.

Keep all guards and shields in good condition and properly installed. Fix damage and replace worn or broken parts immediately. Pay special attention to hydraulic hoses and electrical wiring.



T6607AQ -UN-18OCT88

TX03679.0001734 -19-01SEP06-1/1

Stay Clear of Moving Parts

Entanglements in moving parts can cause serious injury.

Stop engine before examining, adjusting or maintaining any part of machine with moving parts.

Keep guards and shields in place. Replace any guard or shield that has been removed for access as soon as service or repair is complete.

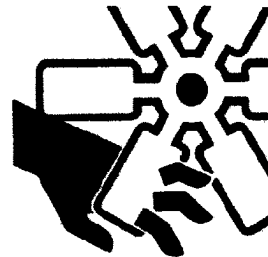

T133592 -UN-12SEP01

TX03679.00016D2 -19-01SEP06-1/1

00
0001
4

Avoid High-Pressure Oil

This machine uses a high-pressure hydraulic system. Escaping oil under pressure can penetrate the skin causing serious injury.

Never search for leaks with your hands. Protect hands. Use a piece of cardboard to find location of escaping oil. Stop engine and relieve pressure before disconnecting lines or working on hydraulic system.

If hydraulic oil penetrates your skin, see a doctor immediately. Injected oil must be removed surgically within hours or gangrene may result. Contact a knowledgeable medical source or the Deere & Company Medical Department in Moline, Illinois, U.S.A.

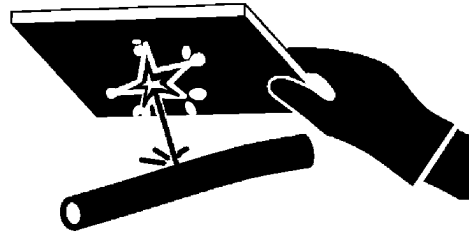
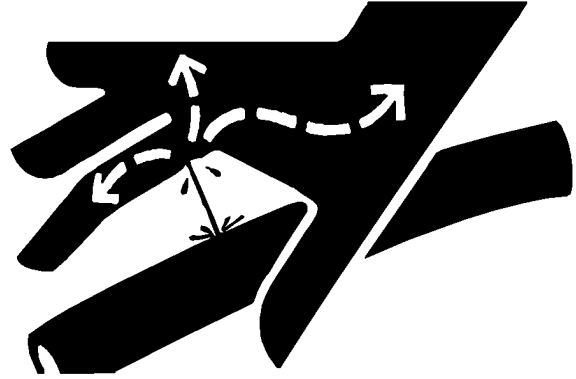

T133509 -JUN-17MAR06

T133840 -JUN-20SEP00

TX03679,00016D3 -19-07SEP06-1/1

Beware of Exhaust Fumes

Prevent asphyxiation. Engine exhaust fumes can cause sickness or death.

If you must operate in a building, provide adequate ventilation. Use an exhaust pipe extension to remove the exhaust fumes or open doors and windows to bring outside air into the area.

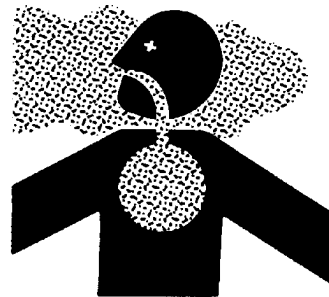

T133546 -JUN-24AUG00

TX03679,00016D4 -19-07SEP06-1/1

Prevent Fires

Handle Fuel Safely: Store flammable fluids away from fire hazards. Never refuel machine while smoking or when near sparks or flame.

Clean Machine Regularly: Keep trash, debris, grease and oil from accumulating in engine compartment, around fuel lines, hydraulic lines and electrical wiring. Never store oily rags or flammable materials inside a machine compartment.

Maintain Hoses and Wiring: Replace hydraulic hoses immediately if they begin to leak, and clean up any oil spills. Examine electrical wiring and connectors frequently for damage.

Keep A Fire Extinguisher Available: Always keep a multi-purpose fire extinguisher on or near the machine. Know how to use extinguisher properly.

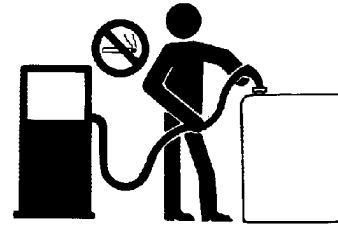

T133552 -UN-14SEP00

T133553 -UN-07SEP00

T133554 -UN-07SEP00

TX03679.00016F5 -19-07SEP06-1/1

Prevent Battery Explosions

Battery gas can explode. Keep sparks, lighted matches, and open flame away from the top of battery.

Never check battery charge by placing a metal object across the posts. Use a voltmeter or hydrometer.

Do not charge a frozen battery; it may explode. Warm battery to 16°C (60°F).



TS204 -UN-23AUG88

TX03679.000174A -19-07SEP06-1/1

00
0001
6

Handle Chemical Products Safely

Exposure to hazardous chemicals can cause serious injury. Under certain conditions, lubricants, coolants, paints and adhesives used with this machine may be hazardous.

If uncertain about safe handling or use of these chemical products, contact your authorized dealer for a Material Safety Data Sheet (MSDS) or go to internet website <http://www.jdmsds.com>. The MSDS describes physical and health hazards, safe use procedures, and emergency response techniques for chemical substances. Follow MSDS recommendations to handle chemical products safely.

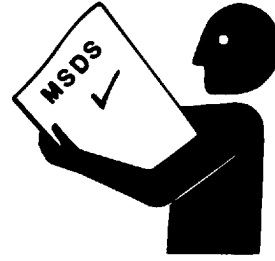

T133580 -UN-25AUG00

TX03679,00016D7 -19-07SEP06-1/1

Dispose of Waste Properly

Improper disposal of waste can threaten the environment. Fuel, oils, coolants, filters and batteries used with this machine may be harmful if not disposed of properly.

Never pour waste onto the ground, down a drain, or into any water source.

Air conditioning refrigerants can damage the atmosphere. Government regulations may require using a certified service center to recover and recycle used refrigerants.

If uncertain about the safe disposal of waste, contact your local environmental or recycling center or your dealer for more information.

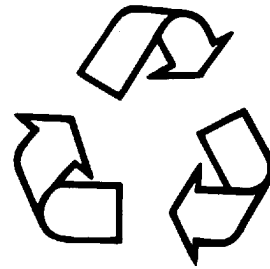

T133567 -UN-25AUG00

TX03679,0001733 -19-07FEB06-1/1

Prepare for Emergencies

Be prepared if an emergency occurs or a fire starts.

Keep a first aid kit and fire extinguisher handy.

Keep emergency numbers for doctors, ambulance service, hospital, and fire department near your telephone.

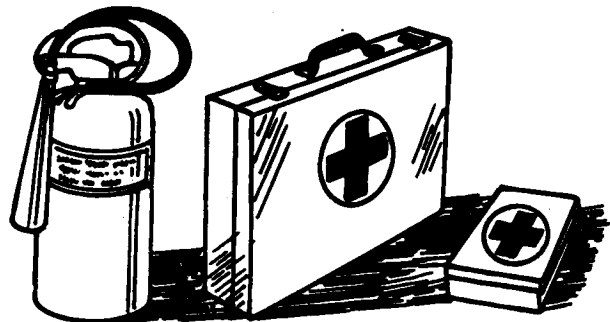

TS291 -UN-23AUG88

TX03679,000174B -19-14SEP00-1/1

Use Steps and Handholds Correctly

Prevent falls by facing the machine when you get on and off. Maintain 3-point contact with steps and handrails. Never use machine controls as handholds.

Use extra care when mud, snow, or moisture present slippery conditions. Keep steps clean and free of grease or oil. Never jump when exiting machine. Never mount or dismount a moving machine.

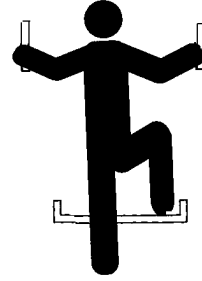

T133468 -UN-30AUG00

TX03679.00016F2 -19-07SEP06-1/1

Start Only From Operator's Seat

Avoid unexpected machine movement. Start engine only while sitting in operator's seat. Ensure all controls and working tools are in proper position for a parked machine.

Never attempt to start engine from the ground. Do not attempt to start engine by shorting across the starter solenoid terminals.



T133715 -UN-07SEP00

TX03679.0001799 -19-07SEP06-1/1

Use and Maintain Seat Belt

Use seat belt when operating machine. Remember to fasten seat belt when loading and unloading from trucks and during other uses.

Examine seat belt frequently. Be sure webbing is not cut or torn. Replace seat belt immediately if any part is damaged or does not function properly.

The complete seat belt assembly should be replaced every three years, regardless of appearance.



**USE
SEAT
BELT**

T133716 -19-14SEP00

TX03679.00016DD -19-07SEP06-1/1

00
0001
8

Prevent Unintended Machine Movement

When co-workers are present, disable hydraulics.

Lower all equipment to the ground during work interruptions. Lock transmission control in neutral, engage park brake and stop engine before allowing anyone to approach the machine.

Follow these same precautions before standing up, leaving the operator's seat, or exiting the machine.

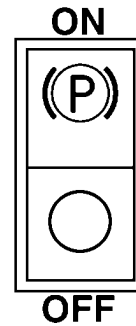

T142001 -UN-15MAY01

TX03679.00017C7 -19-28OCT02-1/1

Avoid Work Site Hazards

Avoid contact with gas lines, buried cables and water lines. Call utility line location services to identify all underground utilities before starting work.

Prepare work site properly. Avoid operating near structures or objects that could fall onto the machine. Clear away debris that could move unexpectedly if run over.

Avoid boom or attachment contact with overhead obstacles or overhead electrical lines. Never move any part of machine or load closer than 3 m (10 ft) plus twice the line insulator length to overhead wires.

Keep bystanders clear at all times. Use barricades or a signal person to keep vehicles and pedestrians away. Use a signal person if moving machine in congested areas or where visibility is restricted. Always keep signal person in view. Coordinate hand signals before starting machine.

Operate only on solid footing with strength sufficient to support machine. Be especially alert working near embankments or excavations.

Avoid working under over-hanging embankments or stockpiles that could collapse on machine.

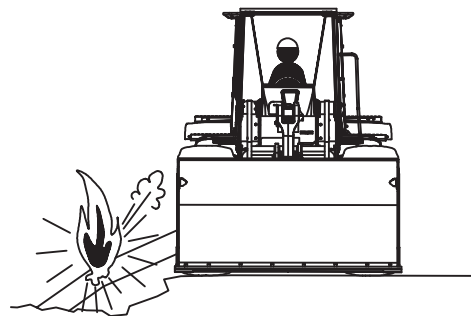

T141894 -UN-15JUN01

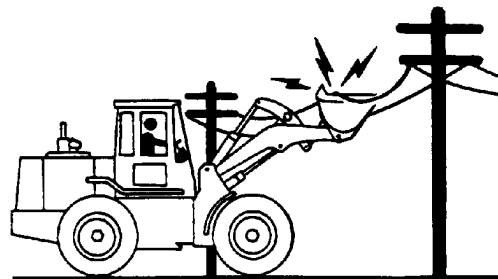

T141670 -UN-24APR01

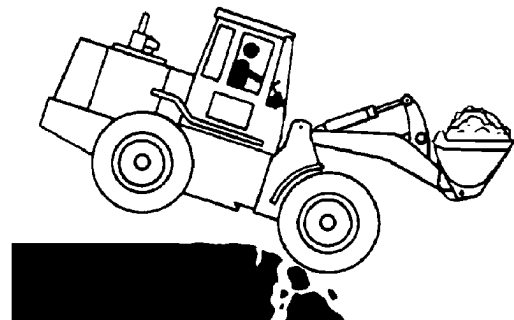

T141672 -UN-04MAY01

TX03679.000179A -19-02MAY01-1/1

Use Special Care When Operating Loader

Never use the loader to lift people. Do not allow anyone to ride in the bucket or use the bucket as a work platform.

Operate carefully with raised loads. Raising the load reduces machine stability, especially on side slopes or an unstable surface. Drive and turn slowly with a raised load.

Ensure that objects in the bucket are secure. Do not attempt to lift or carry objects that are too big or too long to fit inside the bucket unless secured with an adequate chain or other device. Keep bystanders away from raised loads.

Be careful when lifting objects. Never attempt to lift objects too heavy for your machine. Assure machine stability and hydraulic capability with a test lift before attempting other maneuvers. Use an adequate chain or sling and proper rigging techniques to attach and stabilize loads. Never lift an object above or near another person.

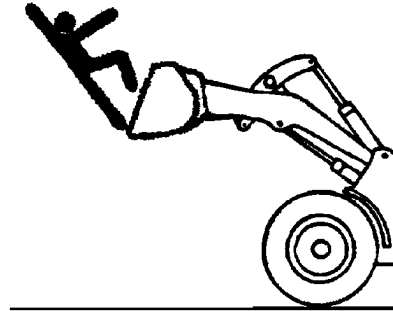

T141957 -UN-15MAY01

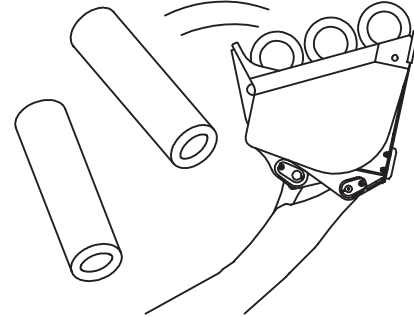

T141902 -UN-07MAY01

TX03768.0000B70 -19-14MAY01-1/1

Keep Riders Off Machine

Only allow operator on machine.

Riders are subject to injury. They may fall from machine, be caught between machine parts, or be struck by foreign objects.

Riders may obstruct operator's view or impair his ability to operate machine safely.

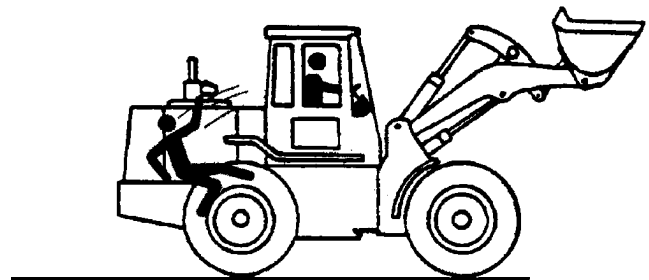

T141671 -UN-04MAY01

TX03679.000179B -19-20APR01-1/1